



US006973864B1

(12) **United States Patent**
Ahmad

(10) **Patent No.:** **US 6,973,864 B1**

(45) **Date of Patent:** **Dec. 13, 2005**

- (54) **PROTECTIVE STRUCTURE AND PROTECTIVE SYSTEM**
- (75) Inventor: **Jameel Ahmad**, Forest Hills, NY (US)
- (73) Assignee: **The Cooper Union for the Advancement of Science and Art**, New York, NY (US)

5,335,472	A *	8/1994	Phillips	52/742.14
5,392,580	A *	2/1995	Baumann	52/660
5,401,120	A *	3/1995	Hussey et al.	405/132
5,470,174	A *	11/1995	Hu et al.	404/52
5,836,715	A *	11/1998	Hendrix et al.	404/134
5,997,792	A *	12/1999	Gordon	264/219

(Continued)

FOREIGN PATENT DOCUMENTS

JP 10-140697 * 5/1998

OTHER PUBLICATIONS

Structural Design For Physical Security: State of the Practice, pp. 4-46 to 4-47 (American Society of Civil Engineers 1999) (ISBN 0-7844-0457-7).

(Continued)

Primary Examiner—Stephen M. Johnson
(74) *Attorney, Agent, or Firm*—Goodwin Procter LLP

(*) Notice: Subject to any disclaimer, the term of this patent is extended or adjusted under 35 U.S.C. 154(b) by 0 days.

(21) Appl. No.: **10/741,307**

(22) Filed: **Dec. 19, 2003**

(51) **Int. Cl.**⁷ **F41H 5/04**

(52) **U.S. Cl.** **89/36.02; 52/742.14; 52/649.1; 52/664; 52/454**

(58) **Field of Search** 89/36.02; 52/742.14, 52/649.1, 660, 661, 664, 673, 676, 431, 432, 52/439, 454

(57) **ABSTRACT**

A protective structure for protecting buildings, bridges, roads and other areas from explosive devices such as car bombs and the like comprises: (a) a mesh structure having an outer surface and an inner surface, wherein the inner surface defines an annular space; (b) a concrete fill material which resides within the annular space of the mesh structure and within the mesh structure; (c) at least one reinforcement member which resides within the concrete fill material; and (d) a concrete face material which resides upon the outer surface of the mesh structure. The mesh structure may be made up of, for example, steel wire. A protective system for protecting buildings, bridges, roads and other areas from explosive devices such as car bombs and the like comprises a plurality of the above described protective structures and a plurality of support members, wherein the support members provide interlocking engagement of the protective structures to the support members.

(56) **References Cited**

U.S. PATENT DOCUMENTS

1,335,780	A *	4/1920	Barton	52/253
1,526,069	A *	2/1925	Irving	404/70
1,554,767	A *	9/1925	Southern	52/649.1
1,645,622	A *	10/1927	Prince	404/70
2,181,466	A *	11/1939	Shackett	52/660
2,669,114	A *	2/1954	Mills	52/454
3,874,134	A *	4/1975	Feldman et al.	52/79.14
3,879,908	A *	4/1975	Weismann	52/309.5
4,454,702	A *	6/1984	Bonilla-Lugo et al.	52/745.13
4,472,919	A *	9/1984	Nourse	52/601
4,706,430	A *	11/1987	Sugita et al.	52/309.16
4,999,965	A *	3/1991	Schmidgall et al.	52/684
5,009,543	A	4/1991	Ahmad	
5,163,263	A *	11/1992	DeSchutter et al.	52/742.14
5,218,809	A *	6/1993	Baumann	52/653.1
5,248,122	A *	9/1993	Graham	249/91
5,291,715	A *	3/1994	Basile	52/687

26 Claims, 5 Drawing Sheets

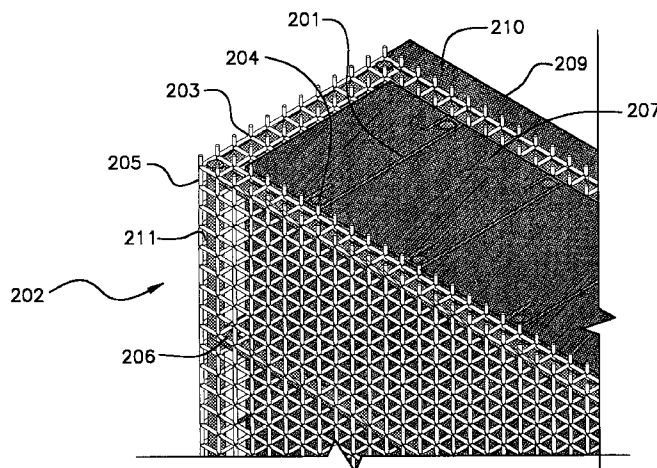

U.S. PATENT DOCUMENTS

6,041,562 A * 3/2000 Martella et al. 52/236.7
6,263,629 B1 * 7/2001 Brown, Jr. 52/309.16
6,305,432 B1 * 10/2001 Sacks et al. 139/425 R
6,412,231 B1 * 7/2002 Palatin 52/79.1
6,438,906 B1 * 8/2002 Komarowski et al. 52/169.1
6,705,055 B2 * 3/2004 Ritter et al. 52/309.11

OTHER PUBLICATIONS

Various excerpts regarding "The Adler Blast Wall(TM)" obtained from <http://www.rsaprotectivatetechnologies.com> printed on Dec. 6, 2003.

Handout regarding "Adler Blast Wall(TM) System" obtained by Dr. Jameel Ahmad in Oct., 2003.

* cited by examiner

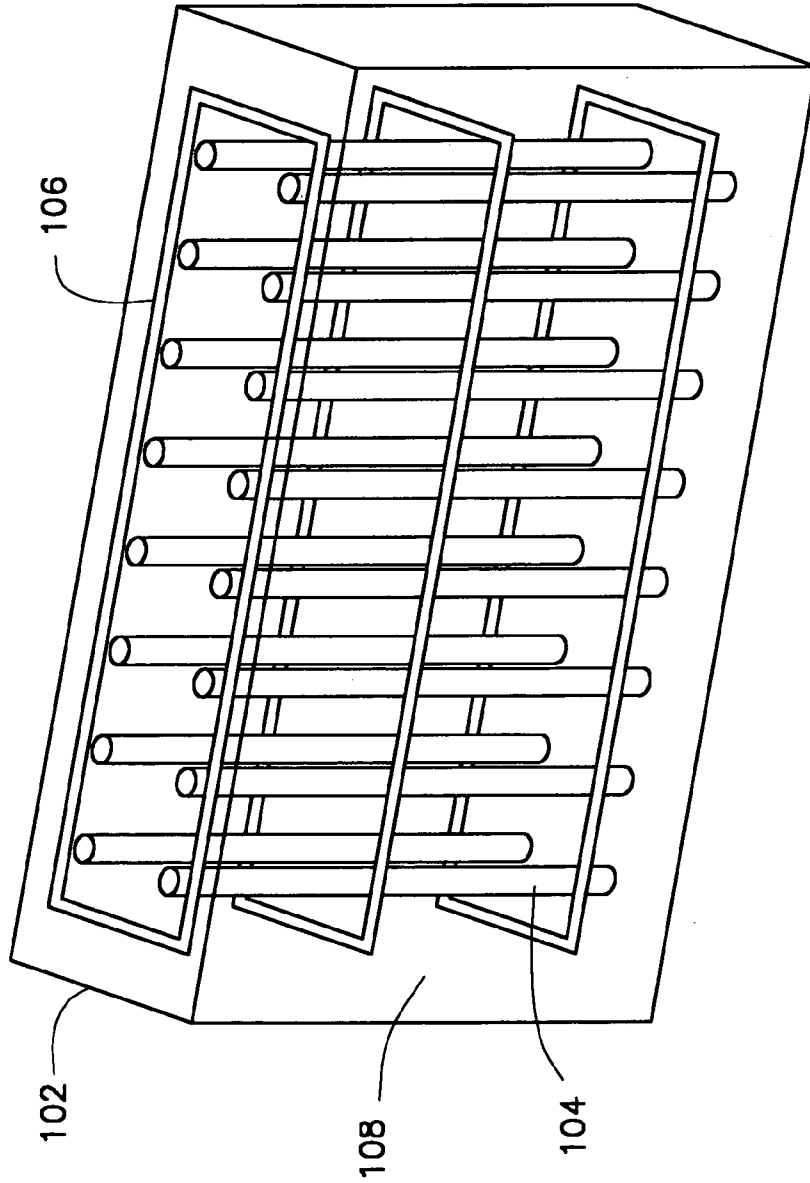

FIG. 1

Prior Art

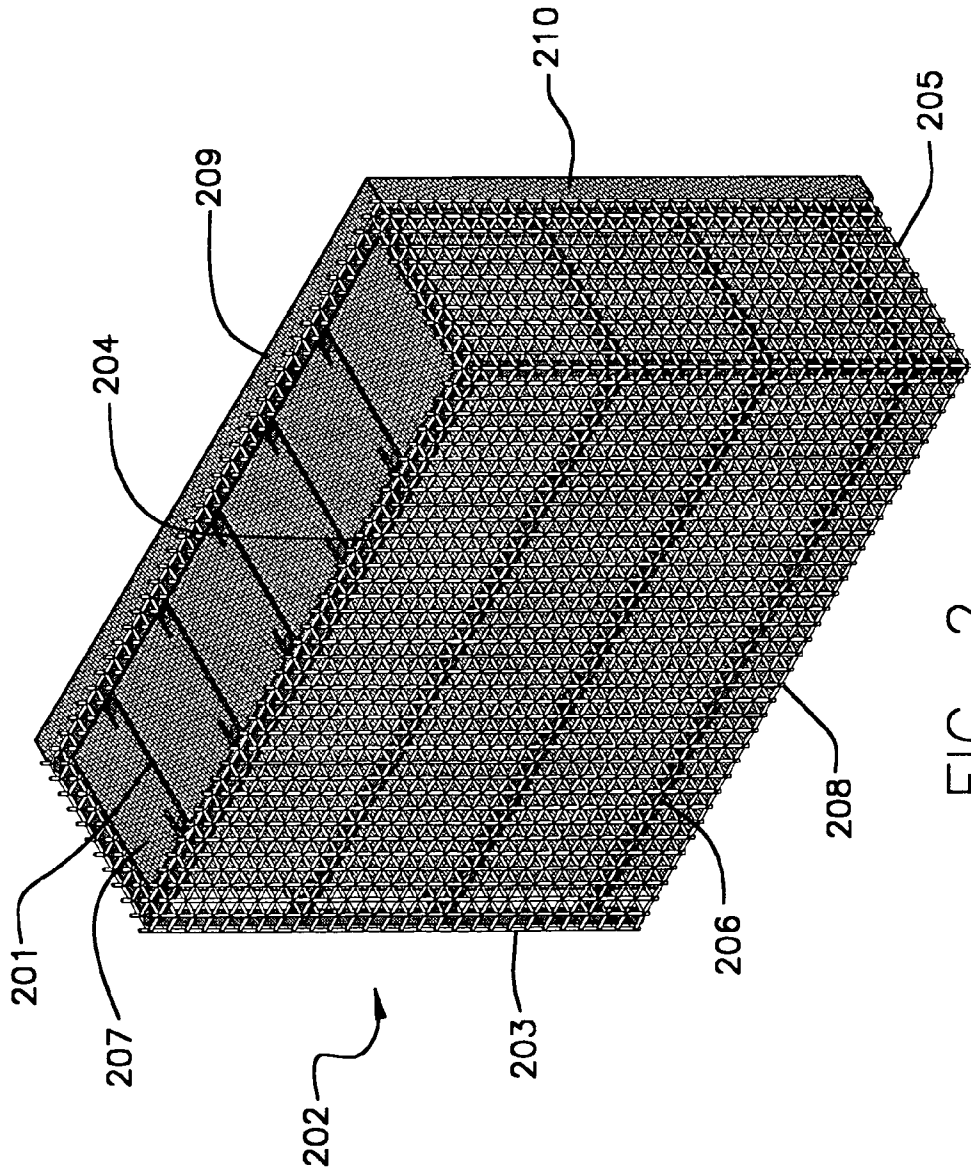

FIG. 2

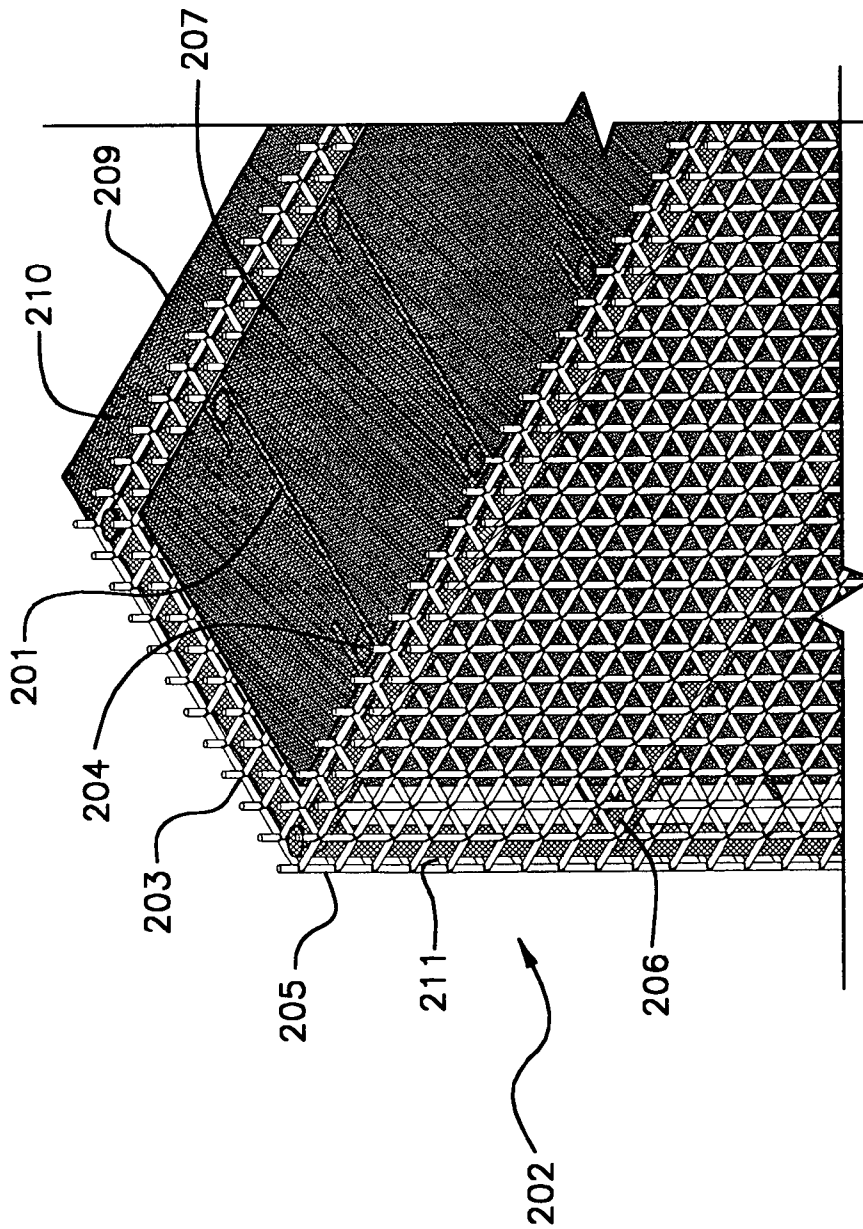

FIG. 2A

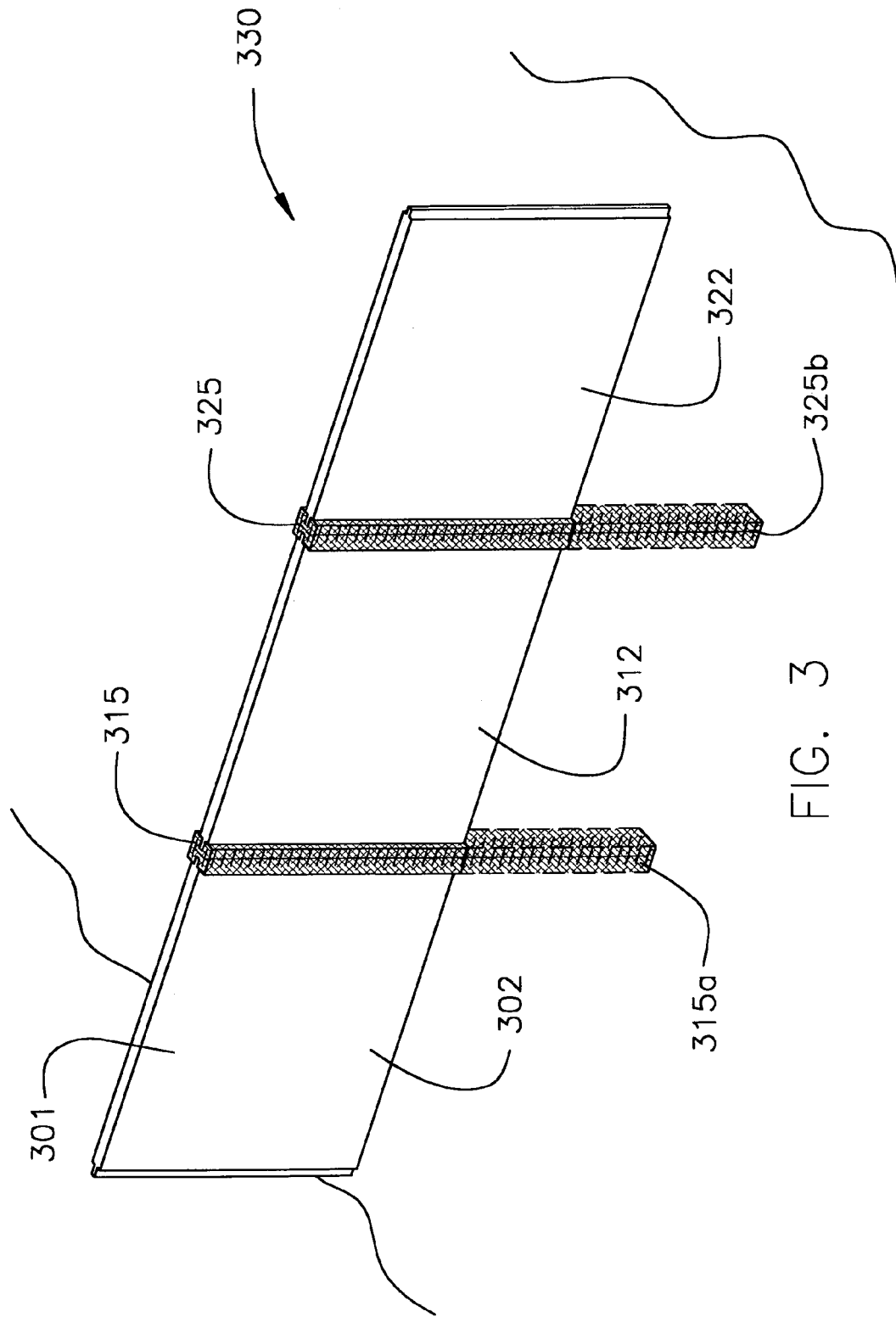

FIG. 3

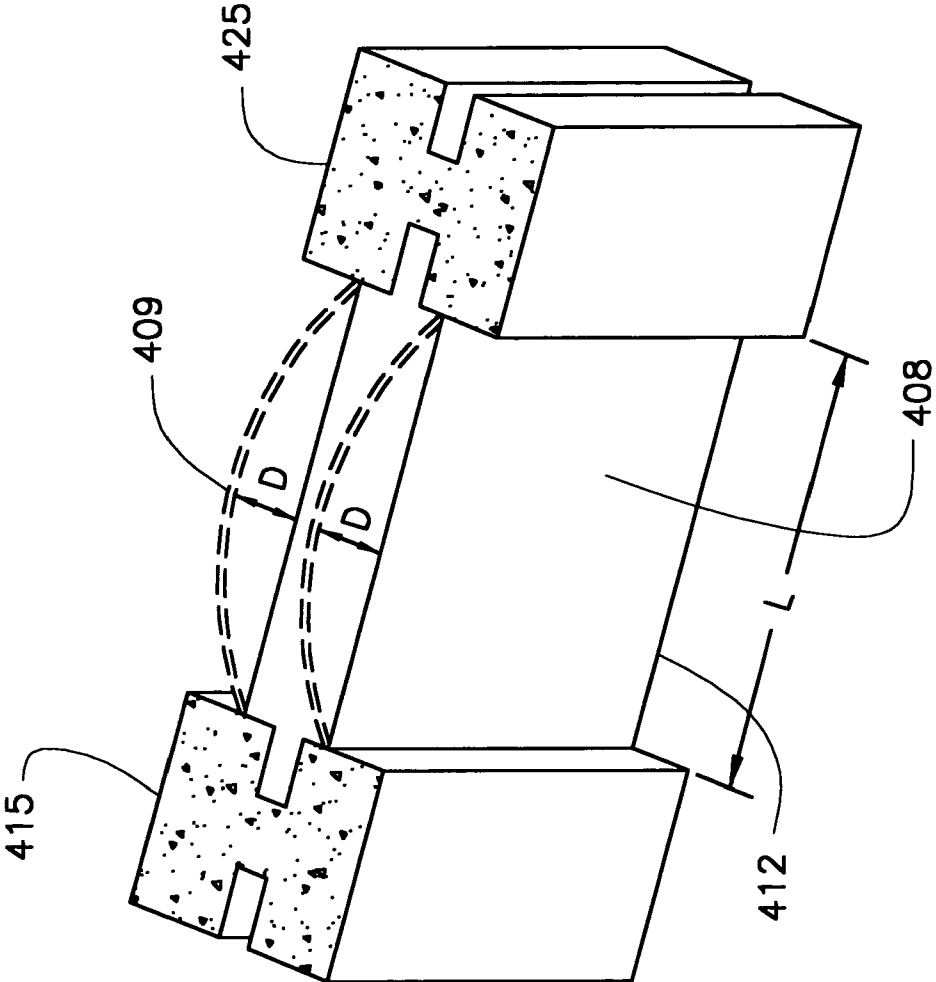

FIG. 4

PROTECTIVE STRUCTURE AND PROTECTIVE SYSTEM

BACKGROUND OF THE INVENTION

1. Field of the Invention

This invention is directed to a protective structure and to a protective system for protecting buildings, streets, and other areas from explosions caused by an explosive device such as a bomb. More particularly, the protective structure and protective system employ a membrane-like mesh structure made up of, for example, steel wire. The mesh structure surrounds a concrete fill material such as reinforced concrete. The protective structure deflects in response to and absorbs the energy associated with the blast load of an explosion, and the mesh structure prevents concrete fragments from injuring people or property in the vicinity of the explosion. The protective structure is sacrificial in nature: i.e. its sole purpose is to absorb the energy from the explosive shock wave and contain concrete debris caused by the explosion. Accordingly, this results in reduction in personal injury and property damage due to the explosion.

2. Background Information

Protection of people, buildings, bridges etc. from attacks by car or truck bombs, remote controlled explosives, etc. is of increasing importance and necessity. The explosive force or pressure wave generated by an explosive device such as a car bomb may be sufficient (depending on the size of the explosive device used) to disintegrate a concrete wall, thereby causing shrapnel-like pieces of concrete to be launched in all directions, and causing additional personal injury and property damage.

Conventional reinforced concrete structures such as reinforced concrete walls are well known to those skilled in the art. Such conventional structures typically employ steel reinforcement bars embedded within the concrete structure or wall. However, in the case of an explosion or blast load which may generate a pressure wave in excess of tens of thousands of psi, a conventional reinforced concrete structure will be ineffective in providing sufficient protection, and the blast load will cause disintegration of the concrete, thereby causing shrapnel-like pieces of concrete to be launched in all directions, and causing additional personal injury and property damage.

One example of a proposed solution for this problem is the Adler Blast Wall™ which is made up of front and back face plates which contain a reinforced concrete fill material. According to the developers of the Adler Blast Wall™, if an explosion occurs proximate to the front face plate, the back face plate will catch any concrete debris which results from the explosion. However, if the back face plate of the Adler Blast Wall™ is sufficiently displaced in the horizontal or vertical direction due to the explosion, small pieces of concrete debris traveling at high velocities may escape, thereby causing personal injury or property damage. Accordingly, there is a need for a protective structure which further minimizes the possibility that such small pieces of concrete debris traveling at high velocities will escape the protective structure employed.

It is a first object of this invention to provide a protective structure which minimizes the possibility that small pieces of concrete debris traveling at high velocities will escape the protective structure in the event of an explosion or blast load proximate to the structure.

It is one feature of the protective structure of this invention that it employs a membrane-like mesh structure made up of, for example, steel wire. The mesh structure is com-

pressible in all three dimensions, and surrounds a concrete fill material such as reinforced concrete. In the event of an explosion proximate to the protective structure of this invention, the mesh structure advantageously prevents concrete fragments produced due to disintegration of the concrete fill material of the protective structure from injuring people or property in the vicinity of the explosion.

It is another feature of the protective structure of this invention that, in the event of an explosion proximate to the protective structure of this invention, the protective structure deflects in response to and absorbs the energy associated with the blast load of the explosion.

It is a second object of this invention to provide a protective system which employs a number of the above described protective structures which are joined together via a number of support members, thereby providing a protective wall of sufficient length to provide more complete protection of a given area as well as additional ease of construction and use.

It is a feature of the protective system of the invention that the support members be capable of receiving the respective ends of the protective structures to provide an integrated wall structure.

It is another feature of the protective system of the invention that the support members may also employ a mesh structure made up of, for example, steel wire. The mesh structure may surround a concrete fill material such as reinforced concrete. Thus, in the event of an explosion proximate to the protective system of this invention, the mesh structure prevents concrete fragments produced due to disintegration of the concrete fill material of the support members from injuring people or property in the vicinity of the explosion.

Other objects, features and advantages of the protective structure and protective system of this invention will be apparent to those skilled in the art in view of the detailed description of the invention set forth herein.

SUMMARY OF THE INVENTION

A protective structure such as a protective wall for protecting buildings, bridges, roads and other areas from explosive devices such as car bombs and the like comprises:

- (a) a mesh structure having an outer surface and an inner surface, wherein the inner surface defines an annular space;
- (b) a concrete fill material which resides within the annular space of the mesh structure and within the mesh structure;
- (c) at least one reinforcement member which resides within the concrete fill material; and
- (d) a concrete face material which resides upon the outer surface of the mesh structure.

A protective system such as a protective wall for protecting buildings, bridges, roads and other areas from explosive devices such as car bombs and the like comprises:

- (I) a plurality of adjacent protective structures, wherein each protective structure has a first end and a second end, and each protective structure comprises:
 - (a) a mesh structure having an outer surface and an inner surface, wherein the inner surface defines an annular space,
 - (b) a concrete fill material which resides within the annular space of the mesh structure and within the mesh structure,
 - (c) at least one reinforcement member which resides within the concrete fill material, and

- (d) a concrete face material which resides upon the outer surface of the mesh structure; and
 (II) a plurality of support members, wherein the support members receive the first or second ends of the protective structures to provide interlocking engagement of the protective structures to the support members.

BRIEF DESCRIPTION OF THE DRAWINGS

FIG. 1 depicts a cross-sectional view of a prior art reinforced concrete wall protective structure.

FIG. 2 depicts a cross-sectional view of one embodiment of the protective structure of this invention.

FIG. 2A depicts a cross-sectional expanded view of a portion of the protective structure of this invention depicted in FIG. 2.

FIG. 3 depicts a front view of one embodiment of the protective system of this invention.

FIG. 4 depicts a cross-sectional view of the deflection of one embodiment of the protective structure of this invention in response to a blast load.

DETAILED DESCRIPTION OF THE INVENTION

This invention will be further understood in view of the following detailed description. Referring now to FIG. 1, there is depicted a cross-sectional view of a prior art reinforced concrete wall protective structure. As shown in FIG. 1, concrete wall 102 contains both vertically placed steel reinforcement bars 104 and horizontally placed steel reinforcement bars 106. If an explosion occurred in the vicinity of the front face 108 of concrete wall 102, the concrete material would disintegrate, and small pieces of concrete debris traveling at high velocities would be produced, thus increasing the possibilities of personal injury and property damage due to such concrete debris.

FIG. 2 depicts a cross-sectional view of one embodiment of the protective structure of this invention. As shown in FIG. 2, concrete wall 202 contains membrane-like mesh structure 203 made up of steel wires 205, as well as vertically placed steel reinforcement bars 204 (connected by steel tie members 201) and horizontally placed steel reinforcement bars 206. Mesh structure 203 defines an annular region which contains concrete fill material 207. Although shown only with respect to the rear face 209 of concrete wall 202, concrete fill material 207 may and preferably does protrude through mesh structure 203 on all sides to provide concrete face material 210. If an explosion occurred in the vicinity of the front face 208 of concrete wall 202, the concrete material would disintegrate, but small pieces of concrete debris traveling at high velocities would be “caught” and contained within the mesh structure 203, thus decreasing the possibilities of personal injury and property damage due to such concrete debris. If desired, one or more additional mesh structures (not shown) may be attached or superimposed upon mesh structure 203, thereby adding additional unit cell thickness and providing additional containment for small pieces of concrete debris generated by disintegration of concrete wall 202 after an explosion.

FIG. 2A depicts a cross-sectional expanded view of a portion of the protective structure of this invention depicted in FIG. 2. As shown in FIG. 2A, concrete wall 202 contains mesh structure 203 made up of steel wires 205 which define mesh structure unit cells 211, as well as vertically placed steel reinforcement bars 204 (connected by steel tie members 201) and horizontally placed steel reinforcement bars

206. Mesh structure 203 defines an annular region which contains concrete fill material 207. The wire mesh which may be employed in the mesh structure is preferably made up of interconnected steel wires. Such steel wires will be selected based upon the assumed maximum blast load, the length of the protective structure, the grade strength of the steel employed in the mesh, and other factors. For example, steel wires having a thickness of 8 gage, 10 gage, 12 gage, or 16 gage may be employed. The mesh structure preferably comprises a plurality of mesh unit cells having a width in the range of about 0.75 to 1.75 inches and a length in the range of about 0.75 to 1.75 inches, although the opening size of the mesh structure may be optimally designed depending upon the properties of the concrete fill material.

It has previously been suggested, for example, in Conrath et al., *Structural Design for Physical Security*, p. 4–46 (American Society of Civil Engineers-Structural Engineering Institute 1999) (ISBN 0-7844-0457-7), that wire mesh may be employed on or just beneath the front and rear surfaces of structural elements to mitigate “scabbing” (i.e. cratering of the front face due to the blast load) and “spalling” (i.e. separation of particles of structural element from the rear face at appropriate particle velocities) for light to moderate blast loads. However, in the protective structure of the present invention, the wire mesh structure employed does not merely mitigate scabbing and spalling for light to moderate blast loads. Instead, the wire mesh structure both prevents spalling at all blast loads (including high blast loads which generate a pressure wave in excess of tens of thousands of psi), and also enables the protective structure to deflect both elastically and inelastically in response to the blast load, as further discussed herein with respect to FIG. 4, such that the energy of the blast load is fully absorbed by the protective structure via large deflections of the protective structure. Due to such large deflections, the wire mesh structure is deformed permanently without any “rebound” back towards its initial position prior to the explosion.

FIG. 3 depicts a front view of one embodiment of the protective system of this invention. As shown in FIG. 3, the protective system 301 includes several protective structures of this invention 302, 312, and 322 which are interconnected via the use of support members 315 and 325. The support members 315 and 325 typically will have a length sufficient to enable the support members to be embedded in the ground for a significant portion of their total length, as shown for example, by support member portions 315a and 325a which are embedded in the ground 330 in FIG. 3.

The embedded depth for the support member portions 315a and 325a in the ground will be determined according to the subsurface soil conditions, as will be recognized by those skilled in the art. For example, in one preferred embodiment, the embedded length of the support member portions in the soil will be a minimum of about one-third of the total length of each support member.

In another preferred embodiment, the support members comprise a mesh structure. The mesh structure of the support members may preferably comprise a plurality of interconnected steel wires. Such steel wires will be selected based upon the assumed maximum blast load, the length of the protective structure, the grade strength of the steel employed in the mesh, and other factors. For example, steel wires having a thickness of 8 gage, 10 gage, 12 gage, or 16 gage may be employed. The mesh structure, if employed, preferably comprises a plurality of mesh unit cells having a width in the range of about 0.75 to 1.75 inches, and a length in the range of about 0.75 to 1.75 inches, although the opening size of the mesh structure may be optimally

designed depending upon the properties of the concrete fill material. The mesh structure, if employed, preferably surrounds a concrete fill material such as reinforced concrete. The concrete fill material preferably protrudes through the mesh structure on all sides to provide a concrete face material for the support member.

FIG. 4 depicts a cross-sectional view of the deflection of one embodiment of the protective structure of this invention in response to a blast load. As shown in FIG. 4, a protective structure of this invention 412 is interconnected to support members 415 and 425. Protective structure 412 has a length L as shown. Upon explosion of an explosive device proximate to the front face 408 of protective structure 412, the wire mesh (not shown in FIG. 4) will deflect in response to the blast load, thereby causing both front face 408 and rear face 409 of protective structure 412 to deflect a distance D (shown in dashed lines). For the protective structure of this invention, which is designed to undergo large deflections to absorb the energy from the explosion, deflection of the protective structure (i.e. the D/L ratio) may be as large as about 25%, say 10–25%.

While not wishing to be limited to any one theory, it is theorized that the deflection of the protective structure of this invention in response to a blast load may be analogized or modeled as wires in tension. Upon explosion of the explosive device and delivery of the blast load to the protective structure, the steel wires of the mesh structure absorb the energy of the blast load. Employing this model, the membrane stiffness of the mesh wire (K) is defined as:

$$K = P_e / D_e$$

where P_e is the load corresponding to the elastic limit of the wire mesh structure and D_e is the deflection corresponding to P_e , and the time period of oscillation of the wire mesh structure (T) (in milliseconds) is defined as:

$$T = 1000 / \omega$$

where ω is the frequency of oscillation in cycles per second (cps), which is defined as

$$\omega = (\frac{1}{2} \pi) (K/m)^{1/2}$$

where m is the mass per foot-width of the mesh structure.

Using the above equations, various design parameters such as the wire gage, size of the mesh unit cell opening, steel grade, etc. may be selected for various blast loads, as set forth in Table 1 below:

TABLE 1

	Wire Gage #	Wire Diameter (in.)	Wire Area(A) (in. ²)	ΣA (in. ²)	R_u (k)	P_e (k)	D_e (in.)	K (#/in)	m (lb - s ² /in.)	ω (cps)	T (milli-seconds)
$F_y = 36$ ksi	16	0.062	0.003	0.290	10.44	1.09	3.77	289	0.0308	15	66
$L_m = 72$ in.	12	0.106	0.0088	0.847	30.48	3.18	3.77	893	0.0899	15	66
	10	0.135	0.014	1.373	49.44	5.16	3.77	1,368	0.1458	15	66
$F_y = 50$ ksi	16	0.062	0.003	0.290	14.50	1.707	4.15	411	0.0308	18.4	54
$L_m = 72$ in.	12	0.106	0.0088	0.847	42.35	4.985	4.15	1201	0.0899	18.4	54
	10	0.135	0.014	1.373	68.65	8.082	4.15	1947	0.1458	18.4	54

where:

ΣA is the sum of the area of the wires per 1 foot-width of mesh structure

R_u is the ultimate load capacity of the wire mesh per foot

F_y is the yield stress of the wire

L_m is the span of the wire mesh structure

As set forth in Table 1, the time period T is a critical design parameter which may be designed for in the protective structure of this invention. For a given explosion or blast load, it is expected that the time duration of the blast load (t_d) will be in the order of a few milliseconds, say 5–10 milliseconds. The mesh structure employed in the protective structure of this invention will be designed such that it will have a time period T much greater than t_d ; typically T is of the order of 5–20 times greater in duration than t_d .

It should be understood that various changes and modifications to the preferred embodiments herein will be apparent to those skilled in the art. Such changes and modifications can be made without departing from the spirit and scope of this invention and without diminishing its attendant advantages. It is therefore intended that such changes and modifications be covered by the appended claims.

What is claimed is:

1. A protective structure for protection from a blast load comprising:

(a) a mesh structure having an outer surface and an inner surface, wherein the inner surface defines an annular space;

(b) a concrete fill material which resides within the annular space of the mesh structure and within the mesh structure, such that the mesh structure surrounds the entire fill material;

(c) at least one reinforcement member which resides within the concrete fill material; and

(d) a concrete face material which resides upon the outer surface of the mesh structure, wherein the blast load has a time duration of t_d , the mesh structure has a time period of oscillation T in response to the blast load, and T is 5–20 times greater than t_d .

2. The protective structure of claim 1, in which the mesh structure comprises a plurality of inter connected steel wires.

3. The protective structure of claim 2, in which the steel wires are selected from the group consisting of 8 gage, 10 gage, 12 gage, or 16 gage steel wires.

4. The protective structure of claim 2, in which the mesh structure comprises a plurality of mesh unit cells having a width in the range of about 0.75 to 1.75 inches and a length in the range of about 0.75 to 1.75 inches.

5. The protective structure of claim 1, in which the concrete fill material permeates through the mesh structure to form the concrete face material.

6. The protective structure of claim 1, in which the reinforcement member is a steel reinforcement bar.

7

7. The protective structure of claim 1, in which the structure contains a plurality of reinforcement members located within the concrete fill material.

8. The protective structure of claim 1, in which the structure deflects in response to a blast load.

9. The protective structure of claim 8, in which the deflection in response to the blast load is 10–25% of the length of the protective structure.

10. The protective structure of claim 1, in which the structure is a wall.

11. A protective system for protection from a blast load comprising:

(I) a plurality of adjacent protective structures, wherein each protective structure has a first end and a second end, and each protective structure comprises:

(a) a mesh structure having an outer surface and an inner surface, wherein the inner surface defines an annular space,

(b) a concrete fill material which resides within the annular space of the mesh structure and within the mesh structure, such that the mesh structure surrounds the entire fill material;

(c) at least one reinforcement member which resides within the concrete material, and

(d) a concrete face material which resides upon the outer surface of the mesh structure, wherein the blast load has a time duration of t_b , the mesh structure has a time period of oscillation T in response to the blast load, and T is 5–20 times greater than t_b ; and

(II) a plurality of support members, wherein the support members receive the first or second ends of the protective structures to provide interlocking engagement of the protective structures to the support members.

12. The protective system of claim 11, in which the mesh structure comprises a plurality of interconnected steel wires.

13. The protective system of claim 12, in which the steel wires are selected from the group consisting of 8 gage, 10 gage, 12 gage, or 16 gage steel wires.

14. The protective system of claim 12, in which the mesh structure comprises a plurality of mesh unit cells having a

8

width in the range of about 0.75 to 1.75 inches and a length in the range of about 0.75 to 1.75 inches.

15. The protective system of claim 11, in which the concrete fill material permeates through the mesh structure to form the concrete face material.

16. The protective system of claim 11, in which the reinforcement member is a steel reinforcement bar.

17. The protective system of claim 11, in which the structure contains a plurality of reinforcement members located within the concrete fill material.

18. The protective system of claim 11, in which the structure deflects in response to a blast load.

19. The protective system of claim 18, in which the deflection in response to the blast load is 25% or less of the length of the structure.

20. The protective system of claim 11, in which the structure is a wall.

21. The protective system of claim 11, in which the support members comprise a mesh structure.

22. The protective system of claim 21, in which the mesh structure of the support members comprises a plurality of interconnected steel wires.

23. The protective system of claim 22, in which the steel wires of the mesh structure of the support members are selected from the group consisting of 8 gage, 10 gage, 12 gage, or 16 gage steel wires.

24. The protective system of claim 22, in which the mesh structure of the support members comprises a plurality of mesh unit cells having a width in the range of about 0.75 to 1.75 inches and a length in the range of about 0.75 to 1.75 inches.

25. The protective system of claim 22, in which the mesh structure of the support members surrounds a concrete fill material such as reinforced concrete.

26. The protective system of claim 25, in which the concrete fill material permeates through the mesh structure of the support members to form a concrete face material for the support members.

* * * * *